

Two Channels. A Powerful Processor.

Shure's DFR has quickly become the industry standard for effective feedback reduction. The DFR22 builds on that reputation to provide an affordable full-featured 2x2 audio processor with Shure's drag-and-drop software. It's much more than feedback reduction. For many jobs, it's the only audio processor you'll need.

The Shure DFR Difference.

Featuring enhancements to Shure's patented Adaptive Notch Filter Algorithm, the DFR22 includes single-channel and stereo processing blocks with up to 16 precision notch filters that automatically seek out and reduce feedback. With widths between 1/10 and 1/70 of an octave, these adaptive filters affect only the problem frequencies, maximizing system stability and sound integrity. In addition, **Auto Clear** mode removes dynamic filters and restores the DFR to your ideally-tuned configuration after a specified amount of time.

Full-Featured Processing Power.

The DFR22 has all of the DSP processing you need to ensure the highest quality audio.

Processors include:

- DFR Automatic Feedback Reducers
- Parametric and Graphic Equalizers
- Cut/Shelf Equalizer
- Compressors/Limiters
- Automatic Gain Control
- Gate/Downward Expander
- Ducker
- 2-Way Crossover
- Subwoofer Processor
- Splitter
- Delay Processors
- 2x2 Matrix Mixer

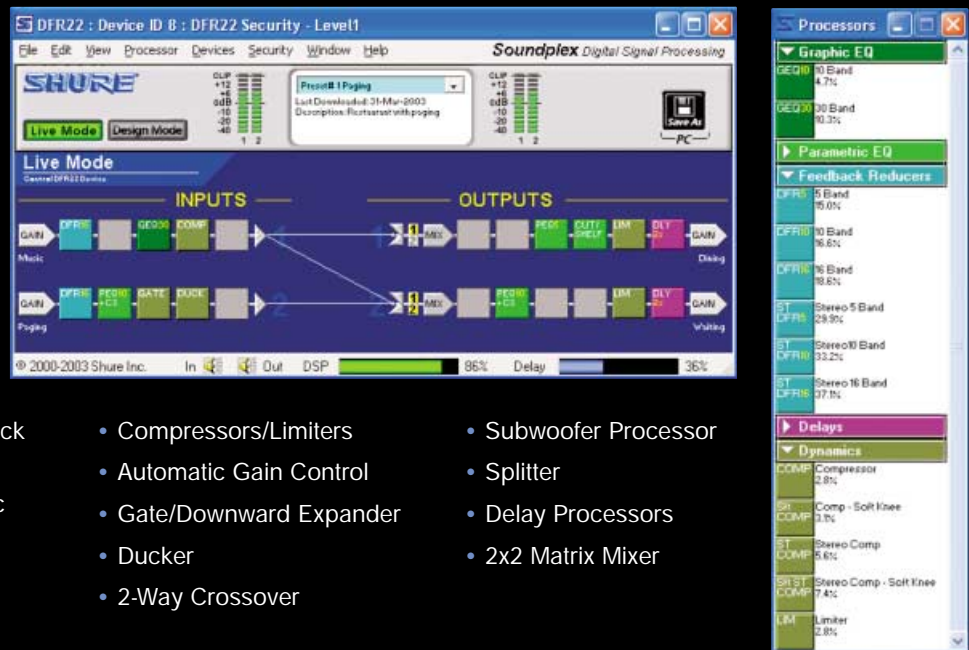

How DFR22 Processes a Stereo Main Mix.



- DFR22 provides:
- Stereo 16-band digital feedback reducer
 - Linked 30-band graphic equalizers
 - Stereo compressor with soft knee
 - Linked 10-band parametric equalizers with additional cut / shelf filters
 - Stereo limiter
 - Up to 2 seconds of delay per channel

How DFR22 Functions

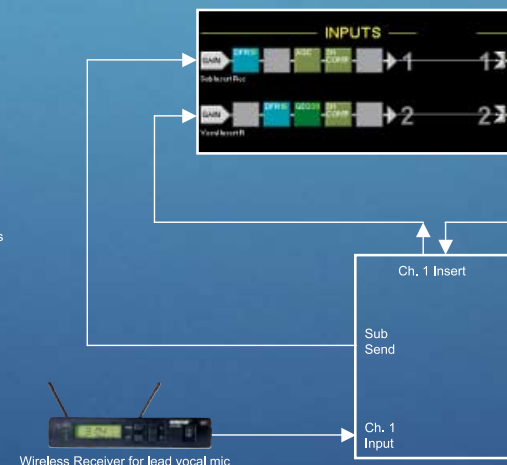

- For subgroup insert, DFR22 provides:
- 16-band digital feedback reducer
 - Automatic Gain Control
 - Soft knee compressor
 - 10-band parametric equalizer
 - Limiter

Flexible. Customizable. Configurable.

Processing blocks in the DFR22 can be applied in any order, to any input or output. You can also link processors for more efficient global control. Copy and paste processing blocks to any input or output to duplicate processors across multiple channels.

With the DFR22, you can design the entire system, save it to disk, and load it at the job site for easy setup. The DFR22 also allows real-time design changes, so you can add, subtract, or change processing blocks as you tune the system. It makes setup a breeze. And ensures that you get the best possible customized processor for your application. Frequency response and signal levels can be visually monitored in real time as parameters are adjusted.

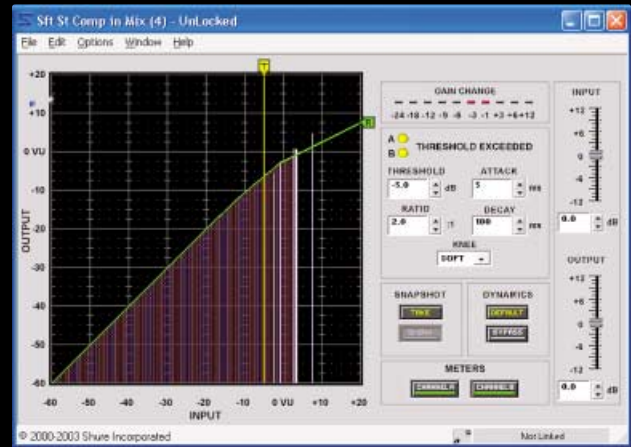
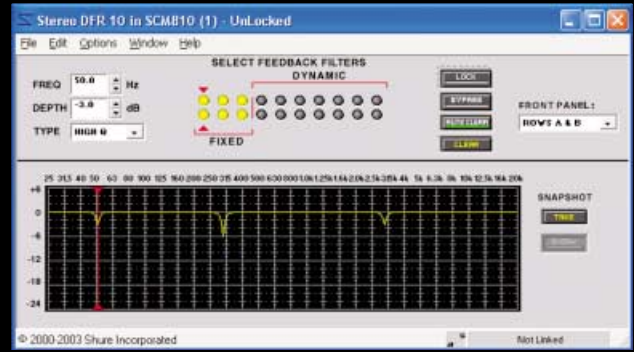

Contact your dealer to experience Soundplex® Smart DSP from Shure.



as an Insert Processor.

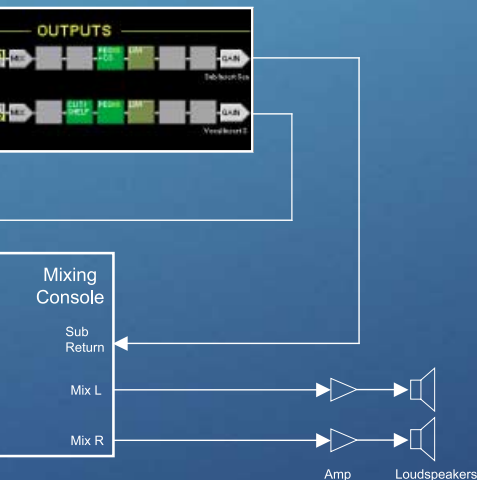

How DFR22 Functions as a Monitor Processor.



For PSM Monitors, DFR22 provides:

- 30-band graphic equalizer
- Soft knee compressor
- 10-band parametric equalizer with additional cut / shelf filters
- Peak stop limiter

For floor wedge monitors, DFR22 provides:

- 16-band digital feedback reducer
- 30-band graphic equalizer
- Soft knee compressor
- 10-band parametric equalizer with additional cut / shelf filters
- Limiter

For lead vocal channel insert, DFR22 provides:

- 16-band digital feedback reducer
- 30-band graphic equalizer
- Soft knee compressor
- Cut / shelf equalizer
- 10-band parametric equalizer
- Limiter

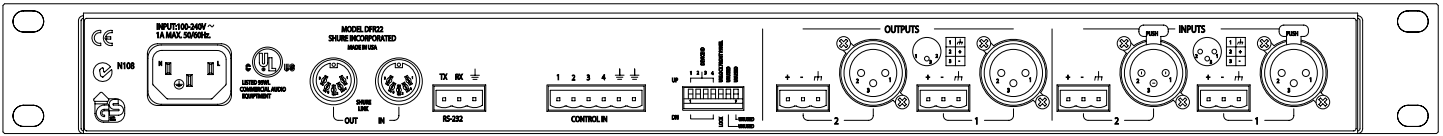
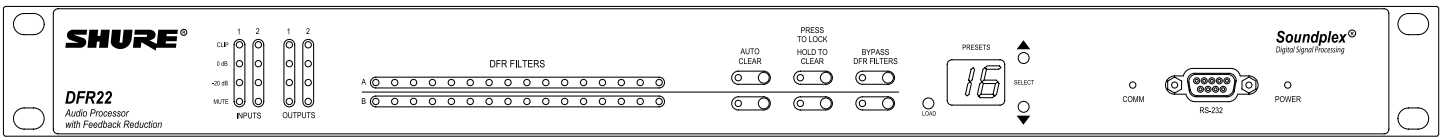

HARDWARE SPECIFICATIONS

Frequency Response

20 Hz to 20 kHz +/- 1 dB

Dynamic Range

110 dB minimum, A-weighted, 20 Hz to 20 kHz

Sampling Rate

48 kHz

Digital-to-Analog, Analog-to-Digital Conversion

24 bit

Impedance

Input: 10 kΩ

Output: 120 Ω

Input Clipping Level

+24 dBu minimum

Output Clipping Level

+24 dBu

+12 dBu (with 12 dB pad)

+6 dBu (with 18 dB pad)

Total Harmonic Distortion

< 0.05%, +4 dBu, 20 Hz to 20 kHz

Propagation Delay from Input to Output

< 1.5 ms. Processing blocks add no latency.

Polarity

Input to output: non-inverting (inverting optional)

Operating Voltage

100-240 Vac, 50/60 Hz (auto-switching), 1 A maximum

Maximum Power Drain

45W

Temperature Range

Operating: -7° to 49° C (19° to 120° F)

Storage: -29° to 74° C (-20° to 165° F)

Dimensions

482.6 mm x 247.7mm x 44.4mm (19 in x 10 in x 1.75 in)

Weight

2.83 kg (6.25 lbs)

Furnished Accessories

Power Cable

5-pin DIN Shure Link Cable

Hardware Kit

5 Block Connector Terminals, 3-pin (for audio inputs and outputs, RS-232)

1 Block Connector Terminal, 6-pin (for control inputs)

4 Rackmount Screws and Washers

Optional Accessories

DRS-10 Wallplate unit with 10-position rotary switch for preset control

SOFTWARE SPECIFICATIONS

DFR

Automatic Feedback Reduction

5-, 10- and 16-filter single-channel and stereo modules

Frequency resolution: 0.1 Hz

Filter width: 1/10 to 1/70 octave

Filter depths: up to 18 dB

EQ & Shelving

Graphic Equalizers

10 and 30 band modules. Combining and Non-combining.

Up to 12dB boost, 18dB cut

Parametric Equalizers

Available in modules with 3, 5, 7, & 10 filters, plus cut/shelf filters

Bandwidth: 1/70 to 4 octaves

Up to 18 dB cut and boost per filter

Cut/Shelf Equalizer

High/Low shelf filters: 6, 12dB/octave slopes, 18dB boost/cut

High/Low cut filters: 6, 12, 18, 24 dB/octave slopes

Cut filter types: Butterworth, Bessel, and Linkwitz-Riley

Delay

Up to 2 seconds per delay block

10 seconds total of available delay memory

20 microsecond resolution

Crossovers and Splitter

Crossovers

2-way crossover and subwoofer modules

Independently adjustable slopes

Butterworth, Bessel, & Linkwitz-Riley up to 24 dB/octave

Adjustable polarity, muting and gain (+/-12 dB) per output

Splitter

2-way splitter

Dynamics Processing

Compressor/ Limiter

Versions Available: Soft/Hard Knee,

Stereo & Peak Stop (look ahead) Limiter

Attack: 1 ms to 200 ms, 0 ms for Peak Stop Limiter

Decay: 50 ms to 1000 ms

Ratio: 1:1 to Infinity:1

Gate and Downward Expander

Ratio 1:1 to Infinity:1

Attack: 1 to 200 ms

Decay: 50 ms to 1000 ms

Gate Hold Time: 0 to 500 ms

Automatic Gain Control

Ratio: 1:1 to 10:1

Attack: 200 ms to 3 seconds

Decay: 500 ms to 5 seconds

Maximum Boost: 12 dB

Ducker

Attack: 1 ms to 5 seconds

Hold: 1 ms to 10 seconds

Release: 1 ms to 10 seconds

Attenuation: 0 dB to - Infinity

Matrix Mixer

Route any input to any output

Independently adjustable crosspoint gain, muting and polarity

SHURE
It's Your Sound®

www.shure.com

United States:
Shure Incorporated
5800 West Touhy Avenue
Niles, IL 60714-4608 USA

Phone: 847-600-2000
Fax: 847-600-1212
E-mail: info@shure.com

Europe:
Shure Europe GmbH
Wannenacker Str. 28,
74078 Heilbronn, Germany

Phone: 49-7131-72140
Fax: 49-7131-721414
E-mail: info@shure.de

Asia:
Shure Asia Limited
Unit 301, 3rd Floor
Citicorp Centre
18, Whitfield Road
Causeway Bay, Hong Kong

Phone: 852-2893-4290
Fax: 852-2893-4055
E-mail: info@shure.com.hk

Elsewhere:
Shure Incorporated
International Americas
Middle East & Africa

Phone: 847-600-2000
Fax: 847-600-6446
E-mail: international@shure.com