

Product Specifications

Beta 54 Subminiature Condenser Headworn Microphone

Overview

Shure model Beta 54 is a subminiature, electret condenser headworn microphone. It provides uncompromised sound quality and reliability with minimal visibility in applications such as broadcast, theater, and touring. Despite its small size, the microphone's condenser element delivers full, clear, and natural reproduction of speech and vocals. The microphone features a durable, low-profile wire frame headband which is fully adjustable for stability and comfort. A plastic carrying case protects the microphone and its accessories.

Features

- Supercardioid polar pattern provides maximum gain-before-feedback and ambient rejection
- Extended frequency response tailored for vocal performances
- Able to handle extremely high sound pressure levels (SPL)
- Snap-fit foam windscreens stay in place during intensive movement
- Available with an in-line preamp or with a TA4F connector for wireless applications
- Choice of black or tan finish to suit your performance environment



BETA 54

Available Models

BETA 54	Subminiature Supercardioid Condenser Headworn Microphone with XLR connection (Black)
WBH54B	Subminiature Supercardioid Condenser Headworn Microphone with TQG connection (Black)
WBH54T	Subminiature Supercardioid Condenser Headworn Microphone with TQG connection (Tan)

Specifications

Cartridge Type	Condenser (electret bias)
Frequency Response	50 to 20,000 Hz
Polar Pattern	Supercardioid
Output Noise (equivalent dB SPL, A-weighted)	39.0 dB typical, 42.0 dB maximum
Signal-to-Noise Ratio	55 dB at 94 dB SPL
Recommended Minimum Input Impedance	>1 k ohms
Preamp Output Impedance	136 ohms
Output Level, open circuit, ref. 1v/Pa at 1 kHz	-52.0 ± 3.0dB 2.51mV
Maximum Sound Pressure Level	149 dB SPL at 1% THD/1 k ohms load
Dynamic Range	110 dB (max. SPL with 1k load, minus typical A-wt. noise)
Current Drain	4.6 mA (preamp and microphone)
Output Polarity Positive pressure on the diaphragm produces a positive voltage at:	Pin 2 relative to pin 3 at the output connector of the preamp
Power Requirements	Phantom power; 11 to 52 Vdc positive on pins 2 and 3, return on pin 1 (ground)
Net Weight	135.35 g (4.75 oz.) microphone and in-line preamp

Furnished Accessories

WA331	4-Pin Mini Connector (TA4F) (1 piece)	RPM626	In-Line Preamp (1 piece)
Black Finish: RPM646	Microphone/Boom Assembly with TA4F Connector (1 piece)	RPM208	Standard Protective Cap (gold mesh) (5 pieces)
RPM510	Swiveling Lapel Clip (5 pieces)	RPM570	Boom Holder and Logo Pad (2 each)
Tan Finish: RPM648	Microphone/Boom Assembly with TA4F Connector (1 piece)	RPM550	Headband (1 piece, with boom holder and logo pad)
RPM512	Swiveling Lapel Clip (5 pieces)	RPM212	Standard Protective Cap (gold mesh) (5 pieces)
		RPM316	Snap-fit Foam Windscreen (4 pieces)
		RPM318	Snap-fit Foam Windscreen (4 pieces)
		RPM580	Boom Holder and Logo Pad (2 each)
		RPM560	Headband (1 piece, with boom holder and logo pad)

Polar Pattern

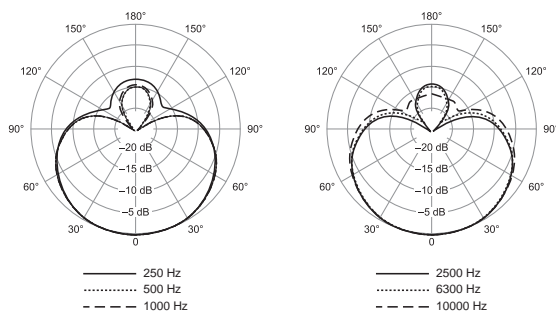

Frequency Response

